

SecuriFire

Extinguishing/Inputs/Outputs unit B6-EIO

Technical Description



Imprint



Notice

This document, T 811 066, is valid only for the product described in Section 1.

This document is subject to change or withdrawal without prior notice. The validity of the statements made in the documentation applies until the statements are revised by a new edition of the documentation (T number with new index). The user of this document is responsible for staying up to date with its current status through the editor/publisher. We accept no responsibility for claims against any incorrect statements in this document which were unknown to the publisher at the time of publication. Handwritten changes and additions are not valid. This document is protected by copyright.

Foreign language documentation as listed in this document is always released or changed at the same time as the German edition. If there are inconsistencies between the foreign language documentation and the German documentation, the German documentation is binding.

Some words in this document are highlighted in **blue**. These are terms and designations which are the same in all languages and are not translated.

Users are encouraged to contact the editor/publisher if there are statements which are unintelligible, misleading, incorrect, or if there are errors.

© Securiton AG, Alpenstrasse 20, 3052 Zollikofen, Switzerland

This document, T 811 066¹, is available in the following languages:

German	T 811 066 de
English	T 811 066 en
French	T 811 066 fr
Swedish	T 811 066 sv

Current edition:

Index a

17.12.2013

Rd

¹ Reference document: B6-EIO, V 1.0

Safety information

Provided the product is deployed by trained and qualified persons in accordance with this document (T 811 066) and the hazard, safety and general information in this technical documentation is observed, there is no danger to persons or property under normal conditions and when used properly.

National and state-specific laws, regulations and guidelines must be observed and adhered to in all cases.

Below are the designations, descriptions and symbols of general, danger, and safety information as found in this document.



Danger

If the Danger notice is not properly observed, the product and other system parts may present a hazard for persons and property, or the product and other system parts may be damaged to the extent that malfunctioning results in danger to persons and property.

- Description of which dangers can occur
- Measures and preventative actions
- How dangers can be averted
- Other safety-relevant information



Warning

The product may be damaged if the safety information is not heeded.

- Description of which damage can occur
- Measures and preventative actions
- How dangers can be averted
- Other safety-relevant information



Notice

The product may malfunction if this notice is not observed.

- Description of which malfunctions can be expected
- Measures and preventative actions
- Other safety-relevant information



Environmental protection / recycling

Neither the product nor product components present a hazard to the environment provided they are handled properly.

- Description of which parts have environmental protection issues
- Description of how devices and their parts have to be disposed of in an environmentally-friendly way
- Description of the recycling possibilities

Document history

First edition Date 04.09.2012

Index „a“ Date 17.12.2013

Most important changes compared with first edition:

Section		New (n) / changed (c) / deleted (d)	What / Reason
• 2.3.1, 2.3.2, 3.2.1, 6.1, 7.1	n	Detectors LKM583 and MMD130 Exi	New added
• 7.3	c	Text: does NOT fulfil the VdS Directive 2489.	Actualisation

Contents

1	General	9
1.1	Validity	9
1.2	General	9
1.3	Compatibility notice	9
2	Design and function	9
2.1	Overview	9
2.2	Interfaces Peripherals are connected with a 16-pin (X4) and two 10-pin (X2 and X3) connector strips.	10
2.3	Connector plugs for detection zones and inputs (X2, X3)	10
2.3.1	Functions	10
2.3.2	Jumper setting	11
2.3.3	Connection assignment for plug (X2)	11
2.3.4	Connection assignment for plug (X3)	11
2.4	Connector plug for monitored outputs (X4)	12
2.4.1	Connection assignment for plug (X4)	12
2.5	Connector plug for LED indication panel (X5)	13
2.5.1	Connection assignment for plug (X5)	13
3	Modes of operation of the inputs	14
3.1	Combination of different modes of operation	14
3.2	“Detection zone” mode of operation	14
3.2.1	SecuriStar detector series 521 / 523 / 563, LKM583, collective MCP	14
3.2.2	Intrinsically safe Ex-i detection zones	14
3.2.3	HX 130 detector series	15
3.3	“Monitored input” mode of operation	16
4	Programming	16
5	Fault displays	16
6	Power requirement	17
6.1	Typical power consumption values for the B6-EIO and peripheral devices	17
6.2	Power requirement calculation	17
7	Connection examples	18
7.1	Connecting the detector series SecuriStar 521 / 523 / 563, LKM583 and MCP 521, 525	18
7.1.1	Connecting detector base USB 501	18
7.1.2	Connecting MCP 525 manual call points	18
7.1.3	Connecting MCP 521N manual call points	18
7.2	Connecting detector base 143 and 143K	19
7.3	Detector base USB 501 with safety barrier Z787	19
7.4	Detector base 143 Ex-i with safety barrier Z787	19
7.5	Detector base 143 Ex-i with direct current isolating transformer GTW 01	20
7.6	Connecting Hochiki Ex-i detectors in Ex areas	20
7.7	Connecting monitored inputs	21
7.8	Connecting extinguishing systems	21
7.8.1	Valve monitoring	21
7.8.2	Extinguishing input in accordance with VdS	21
7.9	Connection of monitored outputs	22
8	Technical data	23
9	Article numbers / spare parts	24
10	List of figures	24

1 General

1.1 Validity

The following documentation is valid for the SecuriFire B6-EIO Unit with edition 20-1100003-01-01.

1.2 General

The B6-EIO ([Extinguishing Input Output](#)) unit is a fixed component of every SecuriFire ECP/FEP 2000 for standards-compliant extinguishing actuation. Additionally, the B6-EIO can be fitted to free slot X5 of any B6-BCB13 main processing unit of the SecuriFire SCP2000 if required and is used for connecting collective detection zones and/or monitored inputs and outputs.

1.3 Compatibility notice



Notice

The B6-EIO is supported beginning with SecuriFire Studio V 1.2.

2 Design and function

The B6-EIO Unit includes 10 monitored inputs and 8 monitored outputs as well as the control electronics for the LED indication panel, which is built into the door of every SecuriFire ECP/FEP 2000.

The unit was developed for standards-compliant actuation of an extinguishing area.

However, in accordance with its features, it can also be used in other ways, for example for connecting a total of 10 detection zones or monitored inputs. Each detection zone or monitored input connection has its own current-limited output driver which supplies the connected peripheral devices with power. The B6-EIO is suitable for combining any mix of monitored inputs as well as for connecting the SecuriStar 521/563 detector series, HX 130, and Hochiki Ex-i detectors.



Fig. 1 B6-EIO

2.1 Overview

The B6-EIO printed circuit board can be used as an option to the SCP2000 and is a fixed component of the FCP2000 and FEP2000. The system connection to the B6-BCB13 is on the rear side using a 48-pin male connector. The fire detection lines / inputs are connected on the front side with two 10-pin plug-in screw terminals; the outputs are connected with a 16-pin plug-in screw terminal.

2.2 Interfaces

Peripherals are connected with a 16-pin (X4) and two 10-pin (X2 and X3) connector strips.

The connection to the LED indication panel of a FCP2000 or FEP2000 is by means of a 12-pin ribbon cable connector plug (X5).

X1	B6-BCD13 connector plug
X2, X3	Connector plug for detection zones and inputs
X4	Connector plug for monitored outputs
X5	Connector plug for LED indication panel
X11 - X20	Jumpers for setting the inputs

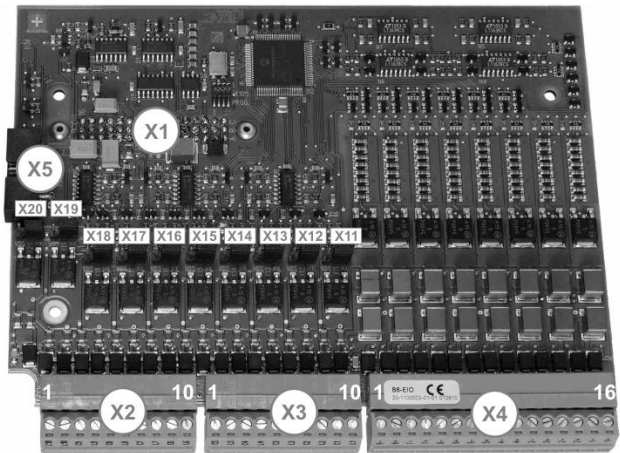

Fig. 2 Interfaces for the B6-EIO

2.3 Connector plugs for detection zones and inputs (X2, X3)

On interfaces X2 and X3, 10 primary inputs or 10 detection zones can be connected (any combination). Every input and line has its own current-limited output driver which supplies the connected peripheral devices with power. The inputs are selectively monitored for short-circuits and wire breakage (according to EN54-13).

The operation mode and subtype selection is carried out individually for each detection zone and input. This is accomplished by means of software planning (SecuriFire Studio) and with jumper settings on the unit.

2.3.1 Functions

The following functions can be planned for each input.

- Inactive
- Monitored input 26K7
- VdS interface
- Input DFG-60 BLK3
- Valve monitoring
- Monitored input 3K
- Series 130/A with pre-alarm
- MMD130 Ex-i, Series 130 Ex-i
- SecuriStar 521/523/563, LKM583, with pre-alarm
- Series 130/A, MCP, without pre-alarm
- SecuriStar 521/523/563, LKM583, MCP without pre-alarm
- SLR-E-IS
- DCD-1E-IS

2.3.2 Jumper setting

The operating mode of the inputs can be set using jumpers X11 to X20. At the same time the corresponding operating mode has to be planned with software (SecuriFire Studio).

The following applies to all jumpers from X11 to X20:



 <p>VDS X HX Jumper HX set</p>	<p>Detection zones</p> <ul style="list-style-type: none"> • SecuriStar 521/523/563, LKM583 • MCP collective • MMD130 Ex-i • HX 130, HX 130 Ex-i 	
 <p>VDS X HX Jumper VDS set</p>	<ul style="list-style-type: none"> • Monitored input 3K • VdS extinguishing input • Valve monitoring • Hochiki Ex-i detector: SLR-E-IS, DCD-1E-IS 	
 <p>VDS X HX Jumper open</p>	<ul style="list-style-type: none"> • Monitored input 26K7 	

Fig. 3 Jumper setting

2.3.3 Connection assignment for plug (X2)

Input no.	Terminal	Designation	Function	Jumper no.
10	1	C10	GND	X20
	2	L10	+24 V	
9	3	C9	GND	X19
	4	L9	+24 V	
8	5	C8	GND	X18
	6	L8	+24 V	
7	7	C7	GND	X17
	8	L7	+24 V	
6	9	C6	GND	X16
	10	L6	+24 V	

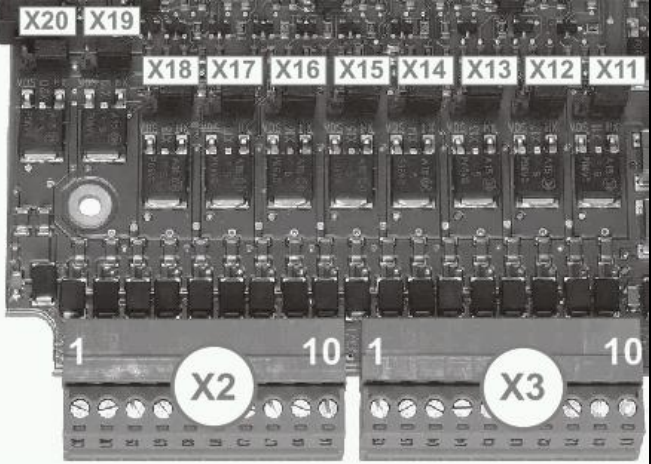
2.3.4 Connection assignment for plug (X3)

Input no.	Terminal	Designation.	Function	Jumper no.
5	1	C5	GND	X15
	2	L5	+24 V	
4	3	C4	GND	X14
	4	L4	+24 V	
3	5	C3	GND	X13
	6	L3	+24 V	
2	7	C2	GND	X12
	8	L2	+24 V	
1	9	C1	GND	X11
	10	L1	+24 V	

2.4 Connector plug for monitored outputs (X4)

The B6-EIO unit is suitable for connecting 8 primary outputs. Every output has its own current-limited output driver which supplies the connected output with power. The outputs are selectively monitored for short-circuits and wire breakage (according to EN54-13). The setting of the load range has to be planned exclusively with software (SecuriFire Studio).



Notice

The total current of all simultaneously activated monitored outputs must not exceed 3.5 A.

Supply voltage::	24V DC (22 ...28V DC)		
Output current::	1,3A max.		
Short-circuit current::	1,77 ... 3.14 A		
Load range::	Range 1	160 Ω to 1k Ω	(monitoring current 1mA)
	Range 2	57 Ω to 375 Ω	(monitoring current 3mA)
	Range 3	20 Ω to 75 Ω	(monitoring current 15mA)
Line resistance::	Range 1	50 Ω max.	
	Range 2:	20 Ω max.	
	Range 3:	5 Ω max.	
Mechanical:	plug-in screw terminal, max. 1.5mm ²		

2.4.1 Connection assignment for plug (X4)

Output no.	Designation	Terminal
8	OM8 -	1
	OM8+	2
7	OM7 -	3
	OM7+	4
6	OM6 -	5
	OM6+	6
5	OM5 -	7
	OM5+	8
4	OM4 -	9
	OM4+	10
3	OM3 -	11
	OM3+	12
2	OM2 -	13
	OM2+	14
1	OM1 -	15
	OM1+	16

2.5 Connector plug for LED indication panel (X5)

The X5 connector plug of the B6-EIO unit is for connecting the LED indication panel for B4-EIP extinguishing areas ([Extinguishing Indication Panel](#)), which is built into the door of every SecuriFire ECP/FEP 2000.

2.5.1 Connection assignment for plug (X5)

Terminal	Designation
1	LINE 0
2	LINE 1
3	LINE 2
4	LINE 3
5	LINE 4
6	LINE 5
7	LINE 6
8	LINE 7
9	COLUMN 0+
10	COLUMN 1+
11	COLUMN 2+
12	KEY+



3 Modes of operation of the inputs

3.1 Combination of different modes of operation

Any function can be assigned and selected for each input.

3.2 “Detection zone” mode of operation



Notice

The following information about the number of detectors per zone is based on the technical system limits and may be restricted by directives and regulations.

3.2.1 SecuriStar detector series 521 / 523 / 563, LKM583, collective MCP

The SecuriStar detector series 521 / 523 / 563, collective MCP function on the basis of the electrical increase principle. This means that all participants of a collective alarm line are switched parallel and supplied with line voltage. At the end of each line a termination resistor is present; it provides quiescent current and thereby stub line monitoring.

In the event of an alarm, the detector internally switches a defined resistance parallel to the alarm line such that there is increased current. The unit monitors each alarm line by means of continuous current measurement, detects the electrical increase and reports an alarm for this detection zone. Short-circuits and wire breakage are reported as faults.

Individual identification is not possible. In the event of an alarm the entire detection zone is displayed in the fire alarm control panel without specifying the detectors that have an alarm status. After a reset the voltage for the entire alarm line is switched off for a few seconds.

Connectable participants

Number of detection zones:	max. 10	
Number of detectors per zone:	SSD 521; MSD 523; SCD 563	max. 30
	UTD 521; UTD 523; TCD 563	max. 30
	LKM 583	30 max.
	MCP 525; MCP 521	max. 30
Connectable detector base:	USB 501x	
Termination resistance:	3 k Ω \pm 5%; 0.5 W	

3.2.2 Intrinsically safe Ex-i detection zones

After parameterising the alarm line as an intrinsically safe detection zone, detectors of the Ex-i series can be connected via a direct voltage isolating transformer or a safety barrier in order to monitor Ex zones.

Intrinsically safe Ex-i Hekatron detection zone via safety barrier Z787 (NOT VdS compliant!)

Number of detection zones:	max. 10	
Number of Ex-i detectors per zone:	MMD 130 Ex- i	max. 10
	ORM 130 Ex-i	max. 10
	WDM 215 Ex-i	max. 10
	WMM 216 Ex-i	max. 10
Connectable Ex-i detector base:	USB501-x, 143 Ex-i	
Termination resistance:	2,7 k Ω \pm 1 %; 1 W	

Intrinsically safe Ex-i Hochiki detection zone via safety barrier Z787 (VdS compliant!)

Number of detectors per zone:	SLR-E-IS	max. 10
	DCD-1E-1S	max. 10
Connectable detector base:	YBN R/4	
Termination resistance:	4.7 k Ω \pm 1%; 0.5 W	

Intrinsically safe Ex-i detection zone via direct voltage isolating transformer GTW 01, GTW 02 (NOT VdS compliant!)

Number of detection zones:	max. 10	
Number of Ex-i detectors per zone:	MMD 130 Ex-i	max. 10
	ORM 130 Ex-i	max. 10
	WDM 215 Ex-i	max. 10
	WMM 216 Ex-i	max. 10
Connectable Ex-i detector base:	USB501-x, 143 Ex-i	
Termination resistance:	4.7 k Ω \pm 1%; 0.6 W	

3.2.3 HX 130 detector series

The HX 130 detector series is based on the same principle as the SecuriStar 521 / 523 / 563 detector series.

Connectable participants

Number of detection zones:	max. 10	
Number of detectors per zone:	ORM 130AY, A/K	max. 30
	WDM 215A	max. 30
	WMM 216A	max. 30
	UFM 840	max. 4
	FT 513	max. 10
	DFM 435 Wx	max. 10
	DFM 435 Kx Ex	max. 10
	ORM 130A Ex	max. 30
	WDM 215A Ex	max. 30
	WMM 216A Ex	max. 30
	UFM 810A Ex	max. 4
Connectable detector base:	143, 143 K	
Termination resistance:	3 k Ω \pm 5%; 0.5 W	

3.3 “Monitored input” mode of operation

The various input types supported by the B6-EIO Unit are all based on the electrical increase principle. A defined resistance on the end of each line serves as line monitor.

If the input is to be switched active, an alarm resistor must be switched parallel to the termination resistance. The value of the alarm resistance is permanently specified based on the set input type. If potential-free contacts are polled, the alarm resistance must be switched in series to the contact.

If the alarm resistance on an input falls below a certain value, a short-circuit fault is output to the SCP specifying the concerned line.

If the termination resistance rises above a certain value (e.g. due to corrosion), the line is detected as interrupted and displayed on the SCP as a wire breakage fault.

Number of inputs: max. 10

	Termination resistance	Alarm resistance
Monitored input 26K7	26.7 k Ω \pm 5%; 0.5 W	18.2 k Ω \pm 5%, 0.5 W
VdS extinguishing interface	3.3 k Ω \pm 5%; 0.5 W	680 Ω \pm 5%, 1 W
Monitored input 3K	3 k Ω \pm 5%; 0.5 W	1.5 k Ω \pm 5%; 0.5 W
Valve monitoring	3 k Ω \pm 5%; 0.5 W	1.5 k Ω \pm 5%, 0.5 W (1.5 k Ω pre-alarm resistance)
Input DFG-60 BLK3	3 k Ω \pm 5%; 0.5 W	1.5 k Ω \pm 5%; 0.5 W



Notice

An actuated alarm resistance is evaluated by the system as “Input active” and does not result in an alarm status.

4 Programming

SecuriFire software documentation for programming and planning is in preparation.

5 Fault displays

The plain text information of a fault code can be called up with the “Additional info” MIC button (magnifying glass).

6 Power requirement



Notice

In the event of a power failure, the fire alarm control panel is powered by batteries. Depending on the configuration and connected peripheral devices (units, detectors, sirens, etc.), it is important to ensure that the batteries have sufficient capacity to operate the fire alarm control panel for the specified time (e.g. according to a standard or directive).

6.1 Typical power consumption values for the B6-EIO and peripheral devices

The power consumption of the unit must also be taken into account when calculating the power requirement:

Type	Designation	Quiescent current	Alarm current
B6-EIO	SecuriFire unit	13.5 mA	13.5 mA

Detectors for HX 130 technology			
Type	Designation	Quiescent current	Alarm current
ORM 130AY	Opt. Smoke detector	100 μ A	22.5 mA
ORM 130A/K	Opt. Smoke detector	100 μ A	22.5 mA
WDM 215A	Heat differential detector	100 μ A	21 mA
WMM 216A	Heat absolute detector	300 μ A	21 mA
UFM 840	Ultraviolet flame detector	800 μ A	25 mA
ORM 130A Ex	Opt. Smoke detector Ex	100 μ A	21 mA
WDM 215A Ex	Heat differential detector Ex	200 μ A	21 mA
WMM 216A Ex	Heat absolute detector Ex	200 μ A	21 mA
UFM 810A Ex	Ultraviolet flame detector Ex	2.7 mA	21 mA
ORM 130 Ex-i	Opt. Smoke detector Ex-i	150 μ A	22 mA
WDM 215 Ex-i	Heat differential detector Ex-i	150 μ A	22 mA
WMM 216 Ex-i	Heat absolute detector Ex-i	150 μ A	22 mA
GTW 01	Direct current isolating transformer	Max. transmission current 33 mA	
GTW 02	Direct current isolating transformer		
DFM 435 Wx	Pushbutton fire alarm	Quiescent no power consumption	18 mA
DFM 435 KL Ex	Pushbutton fire alarm Ex		18 mA
DFM 435 KE Ex	Pushbutton fire alarm Ex		18 mA
DFM 435 KLg Ex	Pushbutton fire alarm Ex		18 mA
DFM 435 KEg Ex	Pushbutton fire alarm Ex		18 mA

Detector series SSD / UTD / MMD130Ex-i, LKM583			
Type	Designation	Quiescent current	Alarm current
SSD 521, SCD563	Scattered-light smoke detector	120 μ A	22.5 mA
UTD 521	Universal temperature detector	150 μ A	22.5 mA
TCD 563	Universal temperature detector	120 μ A	20.0 mA
LKM 583	Ventilation duct smoke detector	not defined yet	not defined yet
MMD 130Ex-i	Smoke and heat detector Ex-i	150 μ A	27.0 mA

6.2 Power requirement calculation

The power requirement calculation is performed by entering the battery types in use and the necessary bridging time (according to local standards and directives) in a power requirement tool.

7 Connection examples

7.1 Connecting the detector series SecuriStar 521 / 523 / 563, LKM583 and MCP 521, 525

7.1.1 Connecting detector base USB 501

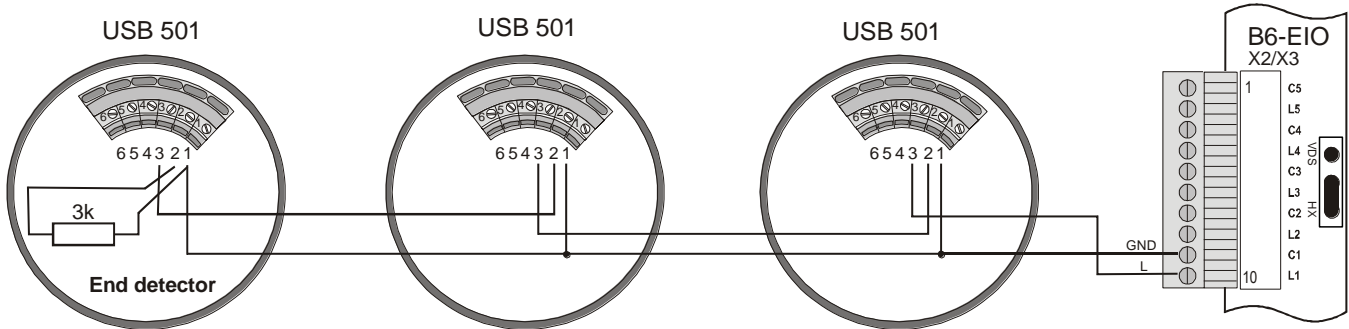

Fig. 4 Connecting the detector series SecuriStar 521 / 523 / 563

7.1.2 Connecting MCP 525 manual call points

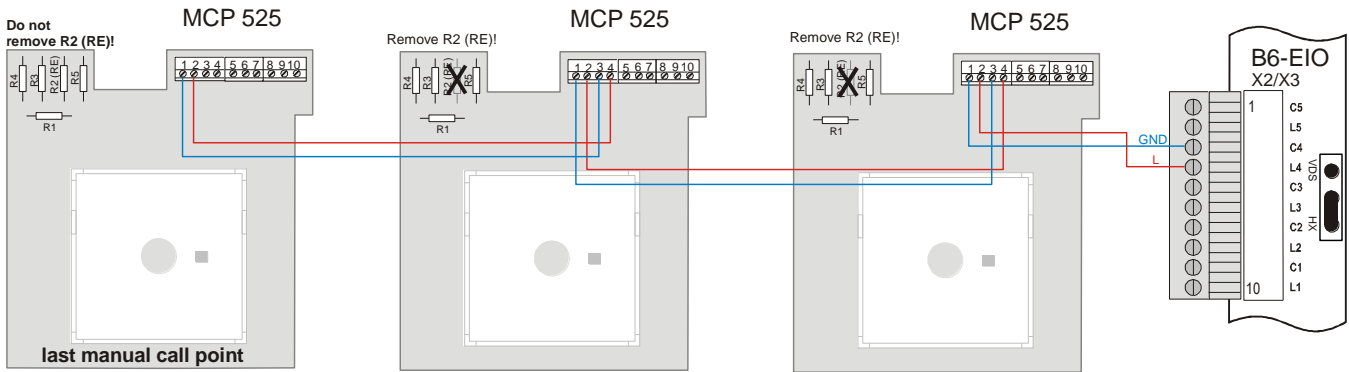

Fig. 5 Connecting MCP 525 manual call points

7.1.3 Connecting MCP 521N manual call points

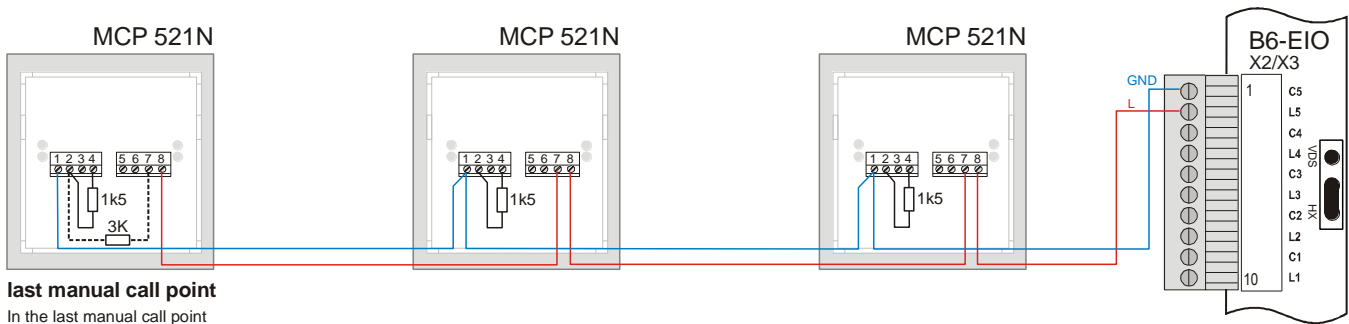

Fig. 6 Connecting MCP 521N manual call points

7.2 Connecting detector base 143 and 143K

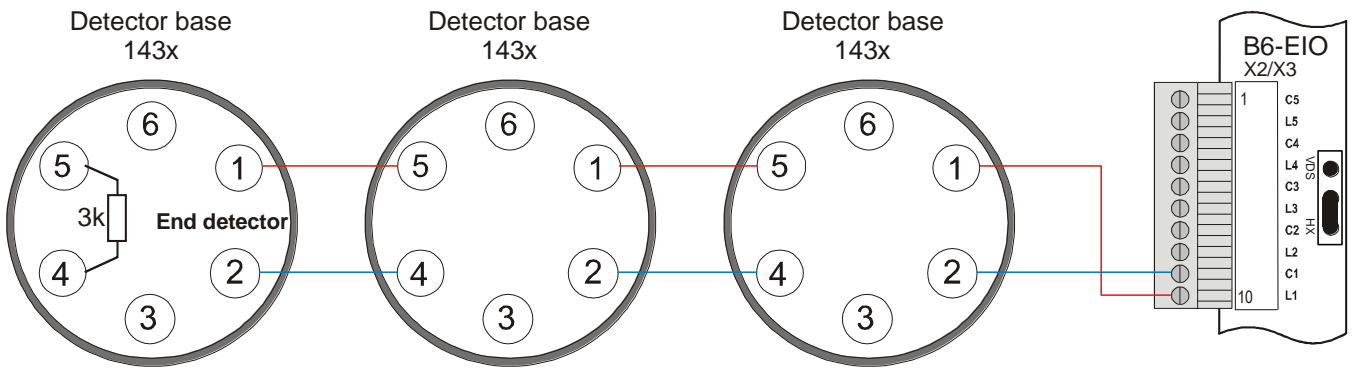



Fig. 7 Connecting detector base 143 and 143K

7.3 Detector base USB 501 with safety barrier Z787



Notice

This connection does **NOT** fulfil the requirements of VdS Directive 2489.

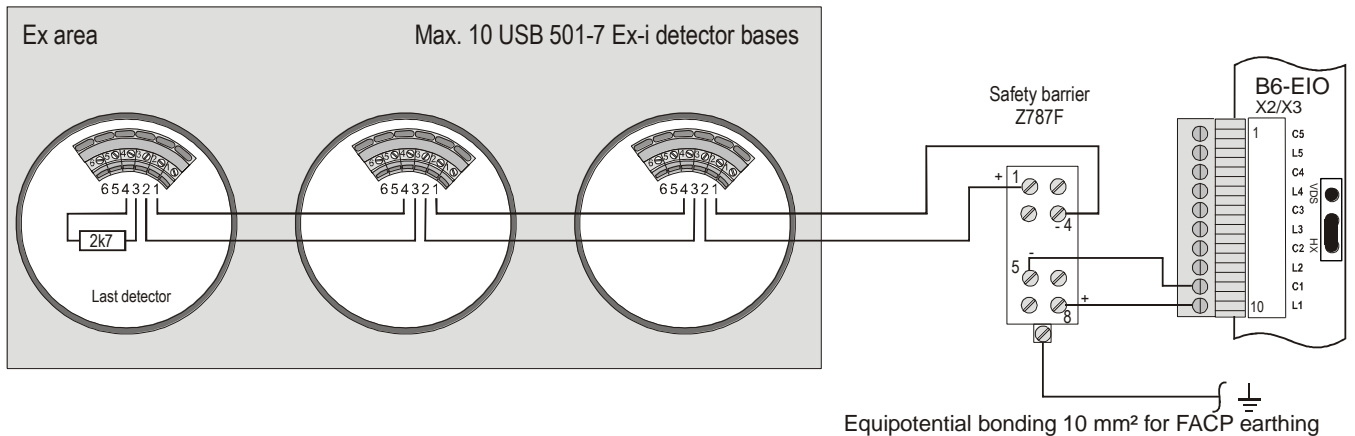

Equipotential bonding 10 mm² for FACP earthing

Fig. 8 Detector base USB 501 with safety barrier Z787

7.4 Detector base 143 Ex-i with safety barrier Z787



Notice

This connection fulfils the requirements of VdS Directive 2489.

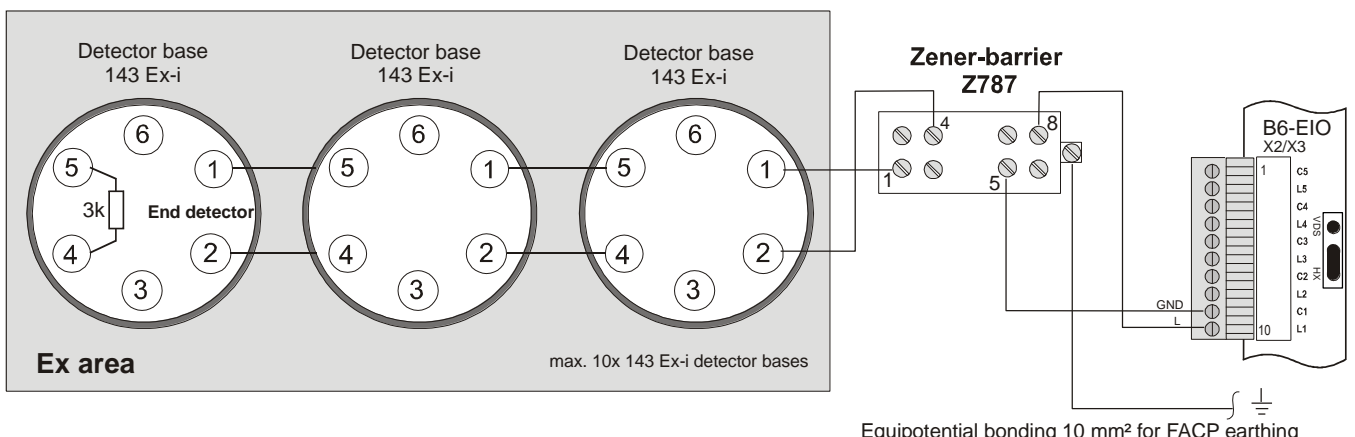

Equipotential bonding 10 mm² for FACP earthing

Fig. 9 Detector base 143 Ex-i with safety barrier Z787

Connection examples

7.5 Detector base 143 Ex-i with direct current isolating transformer GTW 01



Notice

This connection does **NOT** fulfil the requirements of VdS Directive 2489.

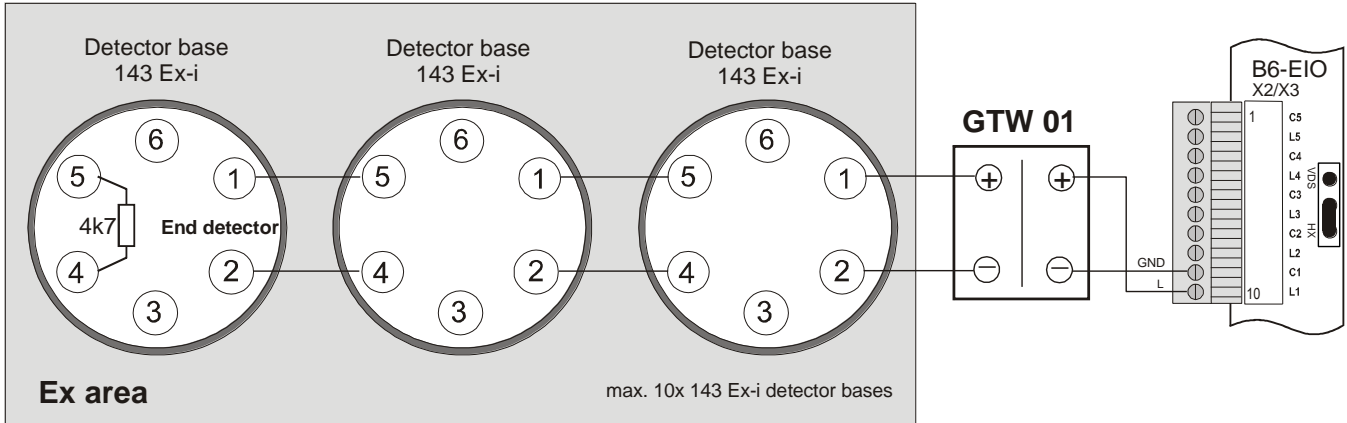

Fig. 10 Detector base 143 Ex-i with direct voltage isolating transformer GTW 01

7.6 Connecting Hochiki Ex-i detectors in Ex areas

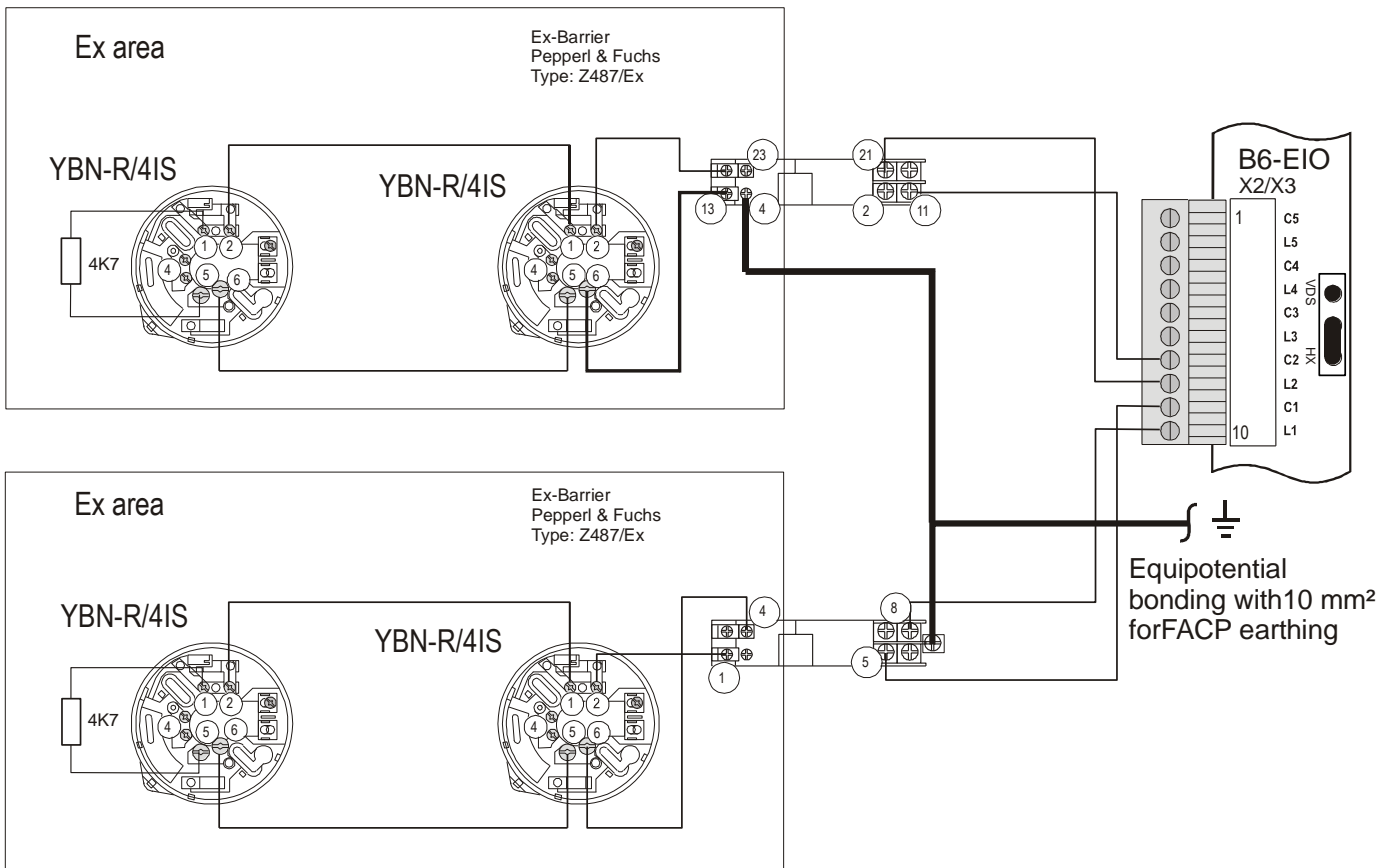

Fig. 11 Connecting Hochiki Ex-i detectors in Ex areas

7.7 Connecting monitored inputs

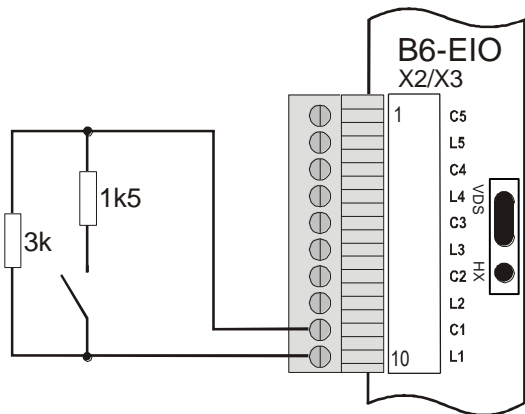

Fig. 12 Monitored input 3K

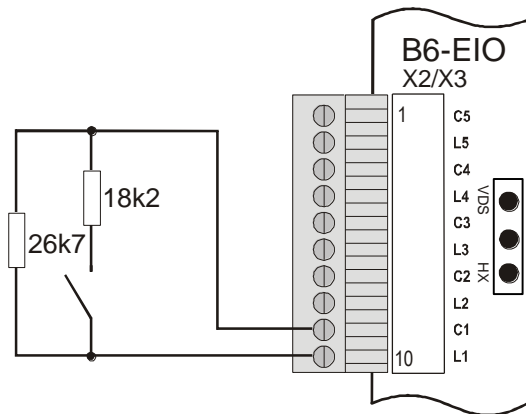

Fig. 13 Monitored input 26K7

7.8 Connecting extinguishing systems

7.8.1 Valve monitoring

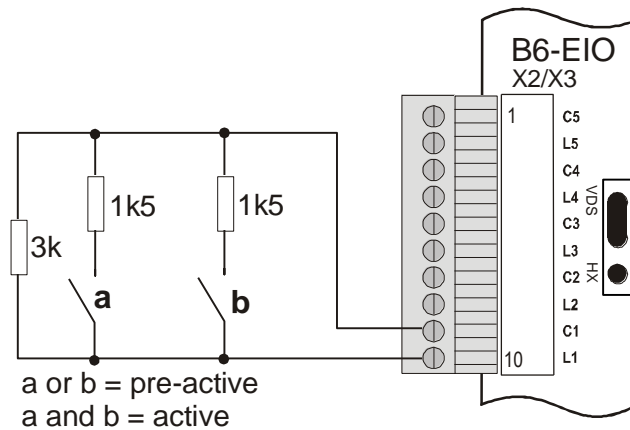

Fig. 14 Valve monitoring

7.8.2 Extinguishing input in accordance with VdS

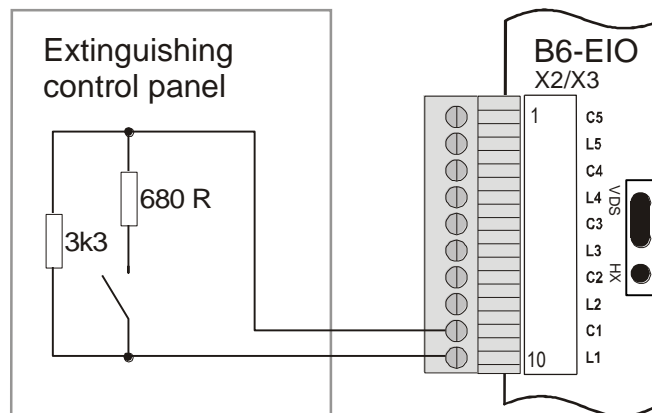

Fig. 15 Extinguishing input in accordance with VdS

7.9 Connection of monitored outputs

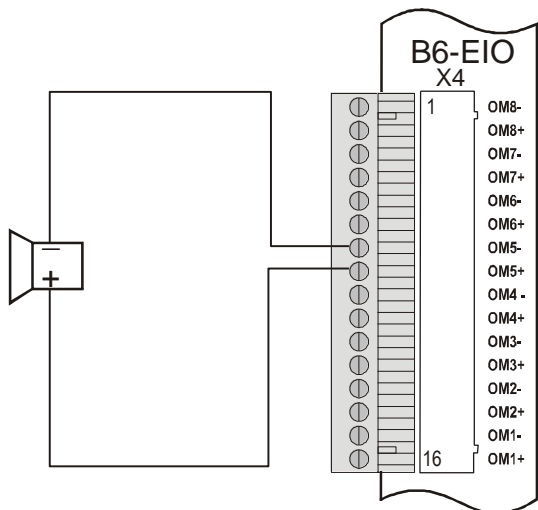

Fig. 16 Quiescent current monitored outputs

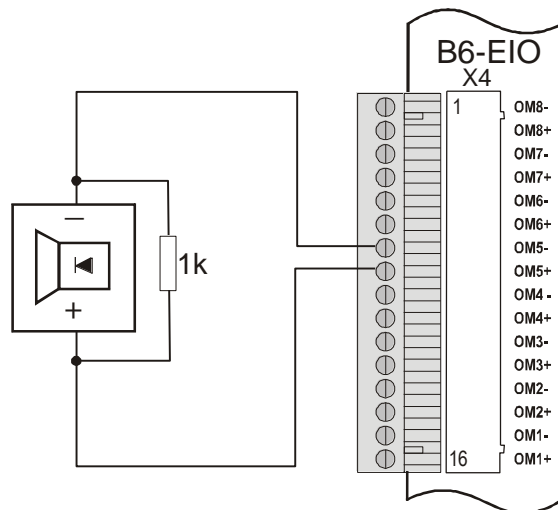

Fig. 17 "Electronic loads"

8 Technical data

Power supply

The power supply of the unit with B6-EIO is via the B6-BCB13 main control unit.

Supply voltage: VP +22 V to +30 V
 VCC 1 +3,4 V ± 2 %
 VCC 2 +5,1 V ± 2 %

Quiescent current consumption: 13.5 mA

Power requirement

	Notice
<p>In the event of a power failure, the fire alarm control panel is powered by batteries. Depending on the configuration and connected peripheral devices (units, detectors, sirens, etc.), it is important to ensure that the batteries have sufficient capacity to operate the fire alarm control panel for the specified time (e.g. according to a standard or directive).</p>	

The power requirement calculation is performed by entering the battery types in use and the necessary bridging time (according to local standards and directives) in a power requirement tool.

Ambient conditions

Ambient temperature: -5°C to +50°C, measured at natural convection under the unit
 Relative humidity: 5% to 95% without condensation
 Air pressure: ≥ 80 kPa, up to 2,000 m above sea level
 Contact protection: IP00, no protection against contact, foreign matter or water

EMC:	EN 50130-4	Electromagnetic compatibility
	EN 61000-6-3	Emission standard for residential environments
	EN 61000-6-2	Immunity for industrial environments
	VdS 2110	Protection against environmental influences
Security:	VDE 0800	Telecommunications – Security
	VDE 0804	Telecommunications – Additional definitions

Dimensions

Unit (H x D x W): 143 x 93.5 x 18 mm

Cable specification

These specifications are relevant to **all** modes of operation!

Max. line resistance: 50 Ω
 Max. cable capacity: 120 nF

Coverage

for 0.6 mm cable cross-section: max. 400 m
 for 0.8 mm cable cross-section: max. 720 m
 for 1.0 mm cable cross-section: max. 1,100 m

Cable type

Suitable cable types are, for example: Red fire detector cable, 2 x 0.6, LF-XY
 Red fire detector cable, 2 x 0.8, J-Y(ST)Y, screened

9 Article numbers / spare parts

Short designation		Swiss art. number	Art. number
Input/output unit	B6-EIO	115.248 126	20-1100003-01-01
	Jumper	239.134 287	

10 List of figures

Fig. 1 B6-EIO	9
Fig. 2 Interfaces for the B6-EIO.....	10
Fig. 3 Jumper setting.....	11
Fig. 4 Connecting the detector series SecuriStar 521 / 523 / 563.....	18
Fig. 5 Connecting MCP 525 manual call points	18
Fig. 6 Connecting MCP 521N manual call points	18
Fig. 7 Connecting detector base 143 and 143K.....	19
Fig. 8 Detector base USB 501 with safety barrier Z787	19
Fig. 9 Detector base 143 Ex-i with safety barrier Z787	19
Fig. 10 Detector base 143 Ex-i with direct voltage isolating transformer GTW 01	20
Fig. 11 Connecting Hochiki Ex-i detectors in Ex areas	20
Fig. 12 Monitored input 3K	21
Fig. 13 Monitored input 26K7	21
Fig. 14 Valve monitoring.....	21
Fig. 15 Extinguishing input in accordance with VdS	21
Fig. 16 Quiescent current monitored outputs.....	22
Fig. 17 "Electronic loads"	22